



PISTON VALVES

YVN - YVNB
YVMN - YVSN

2019 - 01

Piston Valve Working Principle

Sealing System

- Sealing system in the piston valve is enabled by a stainless steel piston and a couple of special elastic rings which surround the piston tightly.
- Sealing surface is the side surface of the piston. While upper ring provides sealing to atmosphere (outside), lower ring provides tightness in the line (inside).
- Leakproofing is provided by tightness in the bonnet nuts acting axially to upper ring. The thrust is transmitted from upper ring to lower ring via lantern bushing. Special elastic rings are thereby compressed and transform this thrust into a radially acting pressure on the piston.
- Elastic rings, being supported against the wall of the valve body, surround the cylindrical piston surface thereby result in an outstanding sealing.

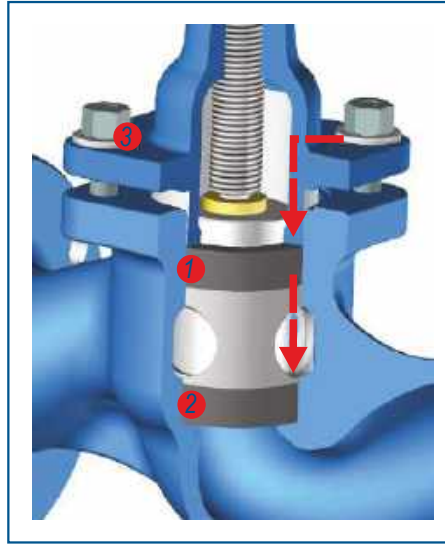

1. YX-GT upper ring
2. YX-GT lower ring
3. Belleville washer

- Layers of YX-GT rings press radially on the sealing surface of the piston
- Belleville washers compensate the pressure and temperature changes. Thereby, a spontaneous and permanent sealing is provided by itself.

Is not affected by unexpected materials flowing in the fluid.
No corrosion on the leakproofing surface.



- There is no direct contact of the piston surface and the fluid. Therefore, there is no corrosion risk for the sealing surfaces. Only the bottom surface of the piston gets into contact with the fluid. This part is not related to the sealing performance.
- Unexpected materials in the medium do not harm a piston valve. When the valve is being shut and the piston enters the lower ring, it sweeps out any particles of sand, welding globules and other impurities existing in the medium. The possibility of damage to the sealing system by abrasive matter existing in the fluid; a well-known problem with seat valves, is eliminated with the piston valves. Fibrous and contaminated media can be reliably shut off without trouble.

- The piston valves of model YVN 15 to 50 have the same sealing system. There is no stuffing box with the ring.
- The balanced piston valves of model YVNB 65 to 200, have stuffing box with the ring. Easy operation is enabled thanks to pressure balance across the piston.
- Ring replacement takes short time, there is no need for difficult mechanical processes like seat grinding etc. for YAKACIK piston valves. A new valve is obtained just by replacing sealing rings. Since they are supported by stainless steel plate, rings have long service life.



No environmental contamination
Saves energy

- YAKACIK piston valves, providing an outstanding leaktightness across both to atmosphere and to line, prevent environmental contamination. Toxic fluids remain in the piping system and are not allowed to diffuse into atmosphere.
- Piston valves save energy via preventing leakage of steam and other power transfer fluids to atmosphere.

Piston Valve YVN 15-50

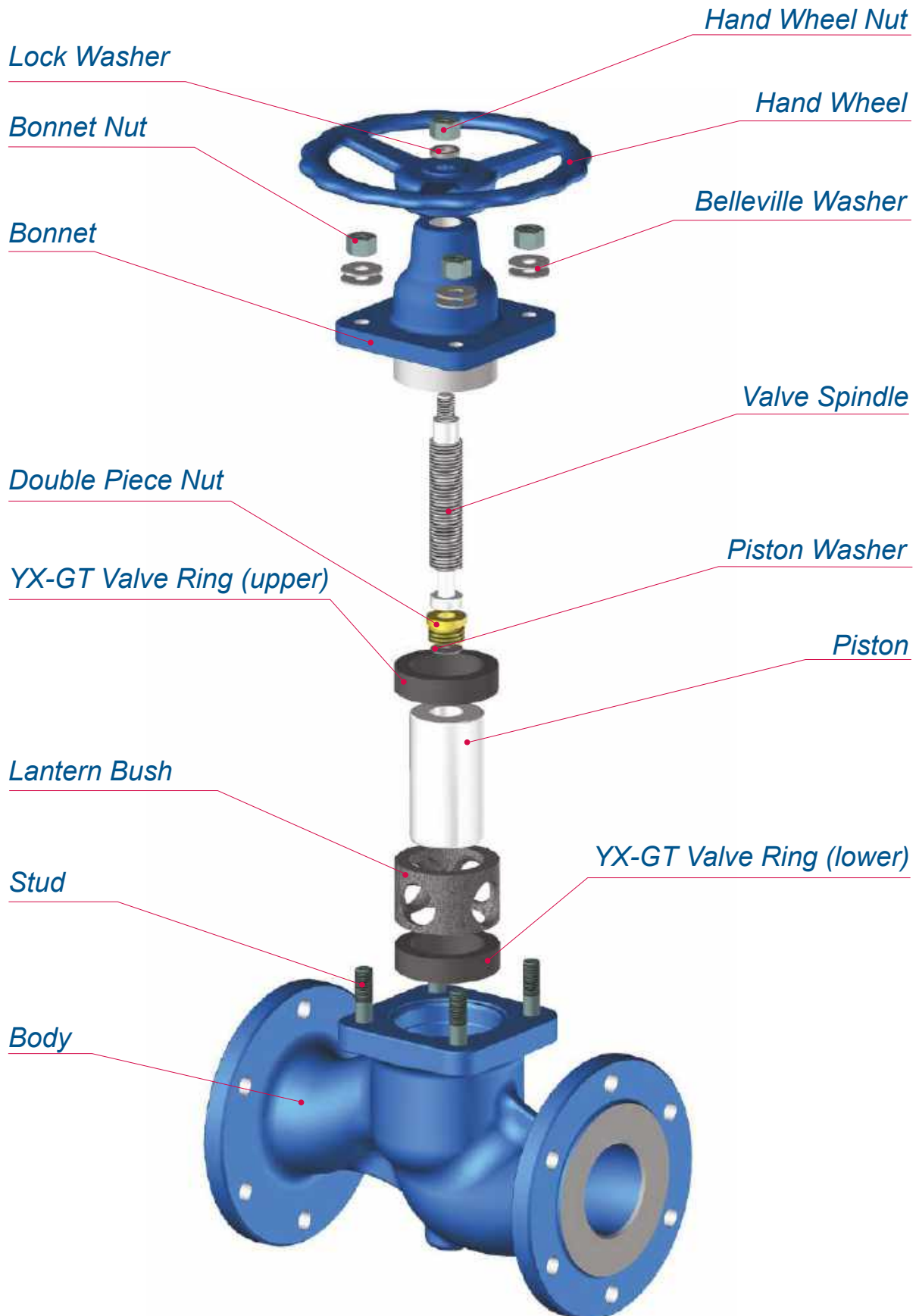

Design and modification rights are reserved

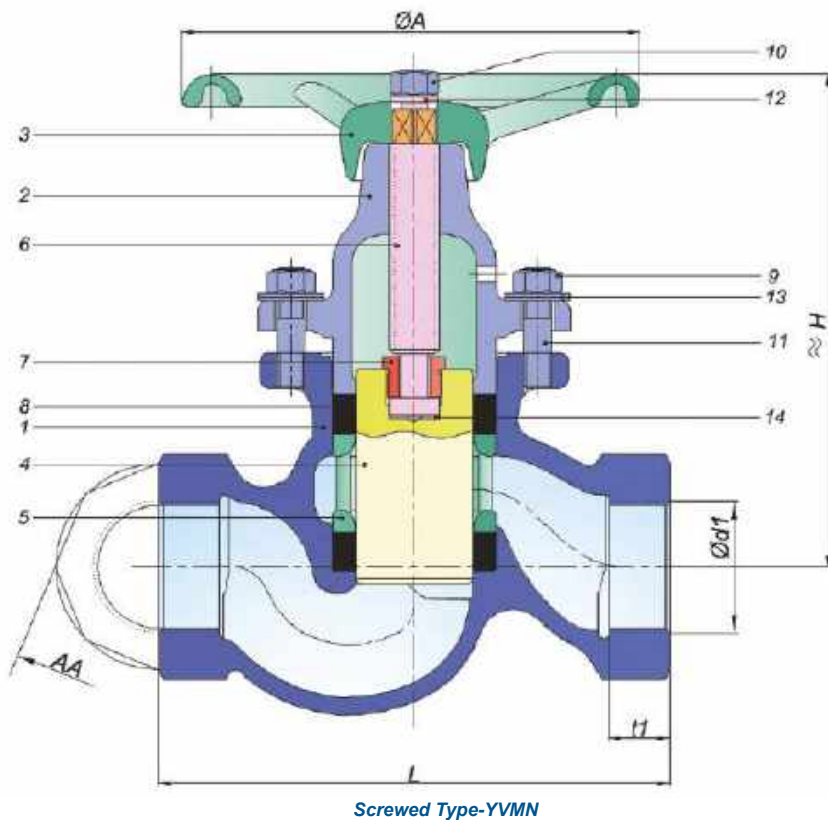

Piston Valves

DN 1/2"-2"

Type: YVMN Screwed YVSN Socket Weld

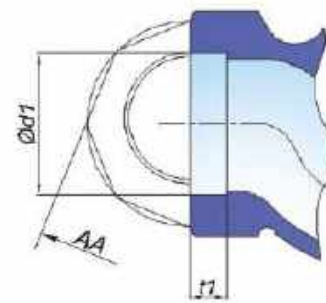

Socket type – YVSN
(For steel and stainless steel)

Material Type	Cast Iron	Cast Steel	Stainless Steel
Size	DN1/4"-2"	DN1/4"-2"	DN1/4"-2"
Pressure Class	PN16	PN40 DN 1/4"-2" PN63 DN 1/4"-1"	PN40 DN 1/4"-2" PN63 DN 1/4"-1"
Dimensions	DIN EN 3202-4/M9 (Except DN 1/4")	DIN EN 3202-4/M9 (Except DN 1/4")	DIN EN 3202-4/M9 (Except DN 1/4")
Assembly (Screwed)	Screwed according to DIN EN ISO 228-1	Screwed according to DIN EN ISO 228-1	Screwed according to DIN EN ISO 228-1
Assembly (Socket)	—	Socketed according to DIN EN 12760*****	Socketed according to DIN EN 12760*****
Temperature	-10°C +300 °C	-10°C * +400 °C	-10°C * +400 °C
Material Code	2	7	9
Order Code (Screwed)	YPG.2M.__.00	YPG.7M.__.00	YPG.9M.__.00
Order Code (Socket)	—	YPG.7S.__.00	YPG.9S.__.00

Fluid Types

All kinds of fluids such as water, hot water, high temperature hot water, steam, thermal oil, LPG, fuel oil, pressurized air, etc.

P.No	Part Name	Cast Iron	Cast Steel	St. Steel	St. Steel
1	Body	GJL 250	1.0619	1.4308	1.4408
2	Upper Bonnet	GJL 250 ****	1.0619 ****	1.4308	1.4408
3	Hand Wheel	GJL 200	GJL 200	GJL 200	GJL 200
4	Piston	1.4021	1.4021	1.4301	1.4401
5	Lantern Bush	GJL 200 + Phosphate	GJL 200 + Phosphate	1.4308***	1.4408***
6	Valve Spindle	1.4021/St-42	1.4021/St-42	1.4301	1.4401
7	Double Piece Nut	Ms-58	Ms-58	1.4301	1.4401
8	Valve Ring	Graphite	Graphite	Graphite	Graphite
9	Nut	8.8+Gal.	8.8+Gal.	A2-70	A2-70
10	Nut	8.8+Gal.	8.8+Gal.	A2-70	A2-70
11	Stud	8.8+Gal.	8.8+Gal.	A2-70	A2-70
12	Lock Washer	8.8+Gal.	8.8+Gal.	A2-70	A2-70
13	Belleville Washer	50CrV4	50CrV4	A2-70	A2-70
14	Piston Washer	Ms-58	Ms-58	1.4301	1.4301

DN		Dimensions			Assembly				
mm	inch	L	H	A	d1		t1		AA
					Screwed	Socket	Screwed	Socket	
6	1/4"	85	105	100	R 1/4"	14.2	10.5	10	32
10	3/8"	85	105	100	R 3/8"	17.6	12.5	10	32
15	1/2"	100	105	100	R 1/2"	22	15.5	10	36
20	3/4"	120	120	120	R 3/4"	27.5	16	13	41
25	1"	135	138	140	R 1"	34.5	19	13	50
32	1 1/4"	160	154	160	R 1 1/4"	43	21	13	65
40	1 1/2"	185	186	180	R 1 1/2"	49	21	13	75
50	2"	220	211	200	R 2"	61.5	26	16	90

* For temperatures below -10°C, stud and nut material should be stainless steel
 ***1.4401 for DN15 and DN20
 **** Ck22 for DN15 and DN20
 *****NPT Screwed type is available according to ANSI 2.1 1960 on demand



PISTON VALVE

Temperature Pressure Diagram

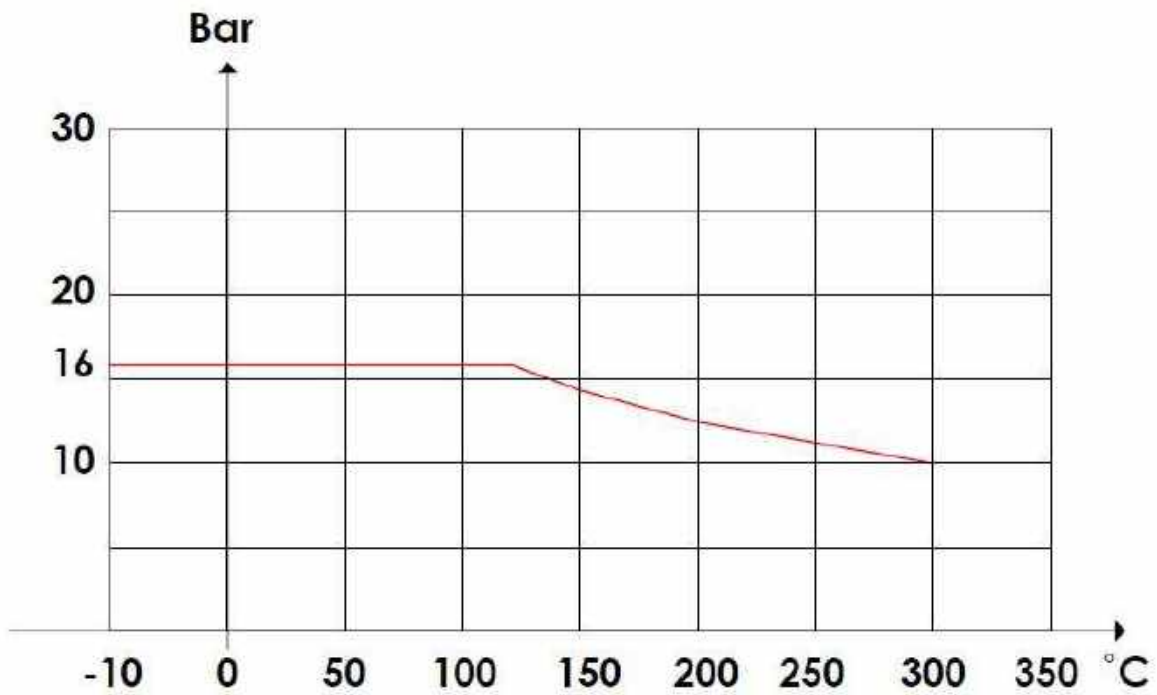

Pressure Class : PN16

Material : GJL 250

PISTON VALVE

Temperature Pressure Diagram



Pressure Class : PN25

Material : 0.7040

PISTON VALVE

Temperature Pressure Diagram

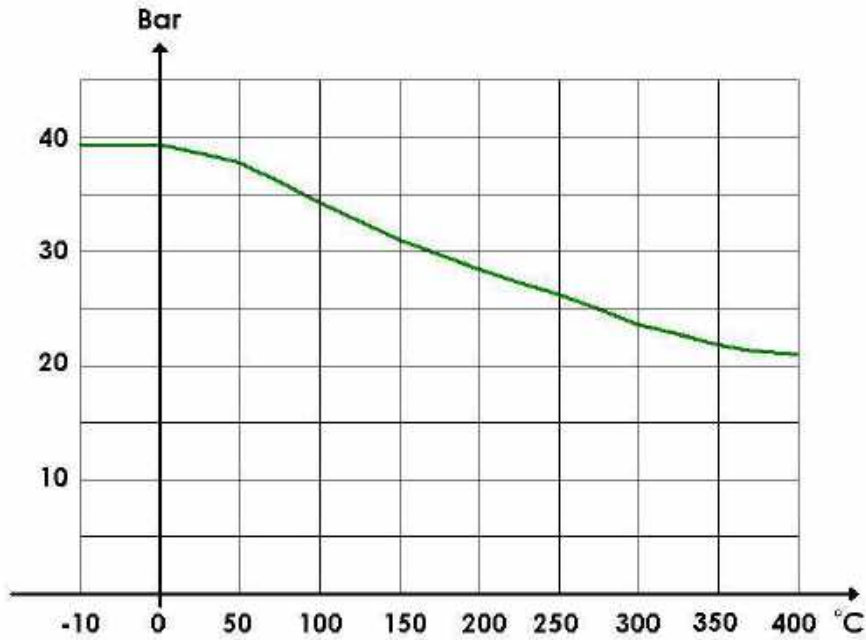

Pressure Class : PN40

Material : 1.0619

Pressure / Temperature Diagrams

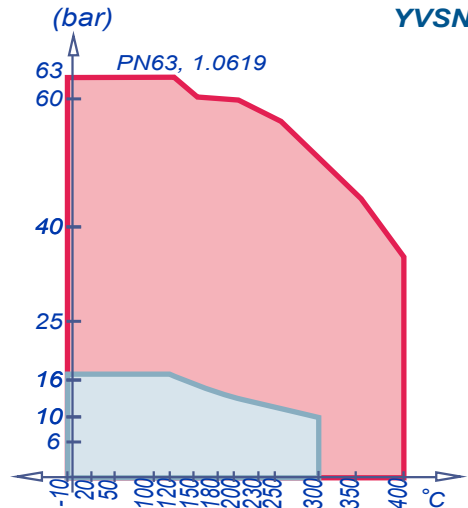
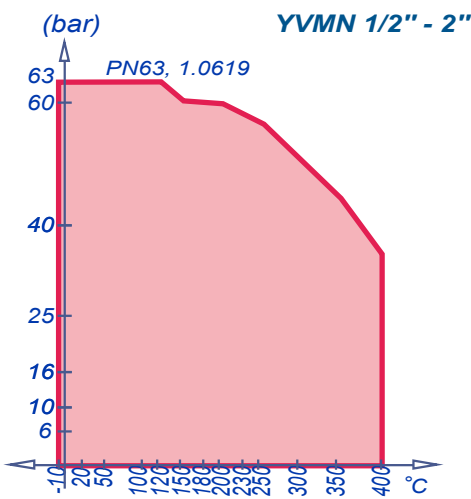
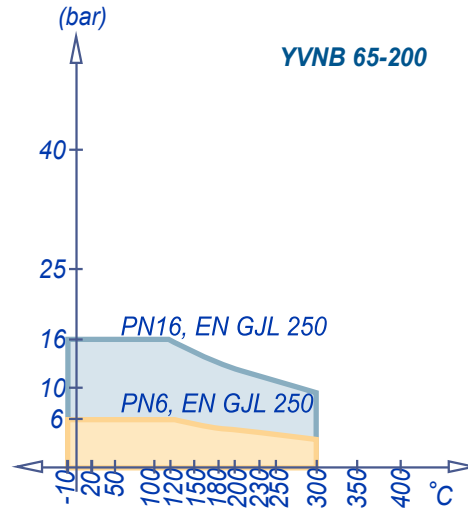
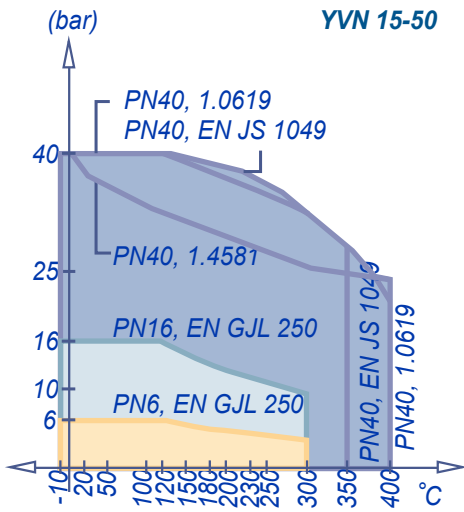

Pressure drop calculation in piston valves

DN	ξ	K_V
15	4	4,5
20	4	8
25	4	12,5
30	4	20,5
40	4	32
50	4	50
65	6	69
80	6	104
100	6	163
125	7,2	233
150	7,2	335
200	7,5	582

Pressure drop formula $\Delta p =$ pressure drop (mmWC)

$$\Delta p = \xi \frac{W^2}{2g} \rho \text{ (mmWC)}$$

$$\Delta p = \left(\frac{Q}{K_V} \right)^2 \times \frac{\rho}{1000}$$

ξ : zeta value
 W : fluid velocity, m/s
 2g : 20 m/s²
 ρ : 1000 kg/m³
 K_v : flow coefficient, m³/h. For $\Delta p = 10$ mWC
 Q : flow rate, m³/h

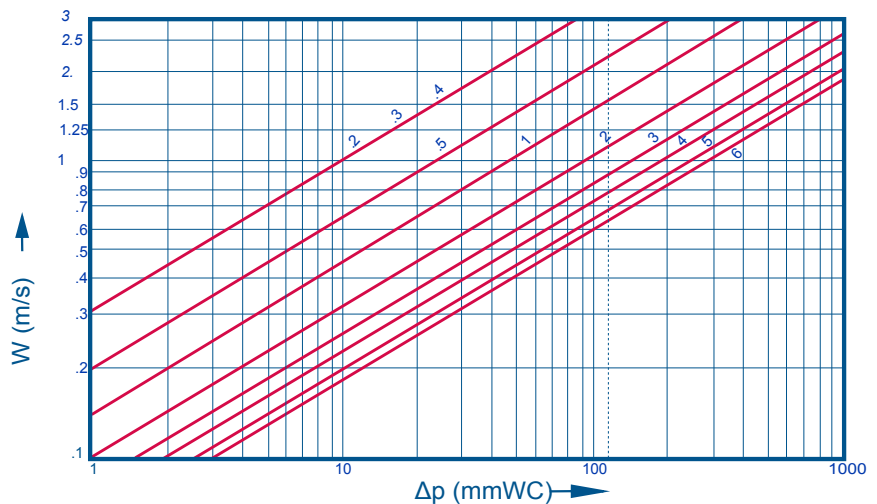

Design and modification rights are reserved